

CWL 30 & 36 CIRCUMFERENTIAL WELD LATHE

FEATURES

- Detachable Fixture Control Pendant
- Headstock: Direct Helical Gear Drive with Monolithic rigid all steel frame
- Bed: Rigid - all steel construction. Saddle & Tailstock ride on precision high capacity preloaded Bearing System
- Tailstock: Rigid all steel construction with full range of alignment adjustment(s)
- Independent Tailstock Pusher System - maintains alignment over full range of thrust
- Torch Head swings to rear of tool for clear access when loading & unloading workpiece
- Detented and Locking Torch Tower Head Pivot for overhead loading

TYPICAL OPTIONS:

Headstock

- Rotary spindle ID gas purge
- Up to 3.00" (5.1 cm) Spindle through hole
- Load capacity to 1,000 lbs (454 kg)

Tailstock

- Rotary gas purge
- Up to 3.00" (5.1 cm) spindle through hole
- Thrust loads to 500 lbs (2,227 N)

Torch Tower

- Motorized z-axis
- Motorized torch mount rotary stage
- Dual Torches

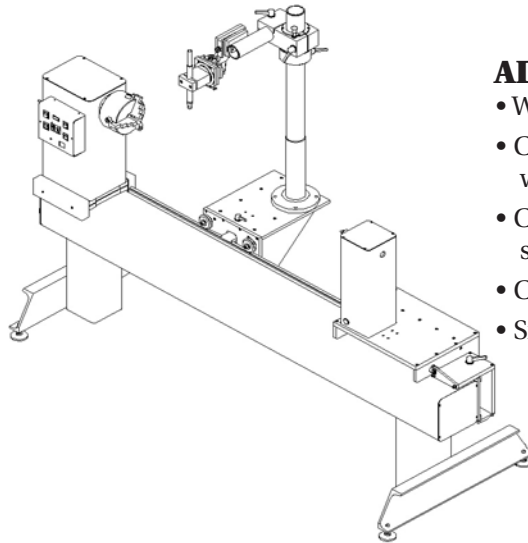

ADDITIONAL OPTIONS:

- Workpiece steady rest(s)
- Custom tooling to hold / locate workpiece
- Computer controlled turn-key systems
- Custom designed positioners
- Side beam carriage

BASIC MODEL NUMBER	DIM A		DIM B		DIM C		DIM D		DIM E		DIM F		DIM G	
	[in]	[cm]	[in]	[cm]	[in]	[cm]	[in]	[cm]	[in]	[cm]	[in]	[cm]	[in]	[cm]
CWL-30-48	48.0	121.9	84.5	214.6	30.0	76.2	21.5	54.6	34.2	86.9	41.6	105.7	62.5	158.8
CWL-30-72	72.0	182.9	108.5	275.6										
CWL-30-120	120.0	304.8	156.5	397.5										
CWL-30-144	144.0	365.8	180.5	458.5										
CWL-36-48	48.0	121.9	84.5	214.6	36.0	91.4	24.5	62.2	37.2	94.5	44.6	113.3	68.5	174.0
CWL-36-72	72.0	182.9	108.5	275.6										
CWL-36-120	120.0	304.8	156.5	397.5										
CWL-36-144	144.0	365.8	180.5	458.5										

(Available in any length)

SPECIFICATIONS

- Input voltage: 100/125 200/250 VAC 50/60 Hz 100 VA
- Shop Air: 90 PSI - filtered
- Speed range .01 ^ 30.00 RPM
- Speed accuracy: 0.10% of full scale
- T.I.R. .001 in .025 mm
- Weld current capacity: up to 300 Amps
- Spindle through hole: 1.27 in 3.22 cm
- Tailstock stroke 3.00 in 76 mm / live center
- Maximum tailstock thrust force (90 PSI Shop air): 160 lbs. 708 N
- Workpiece weight capacity: 250 lbs. 113 kg

