

Combo HDH Heavy Duty Two-Roll Bending System & PLS-24 Longitudinal Seam Welder

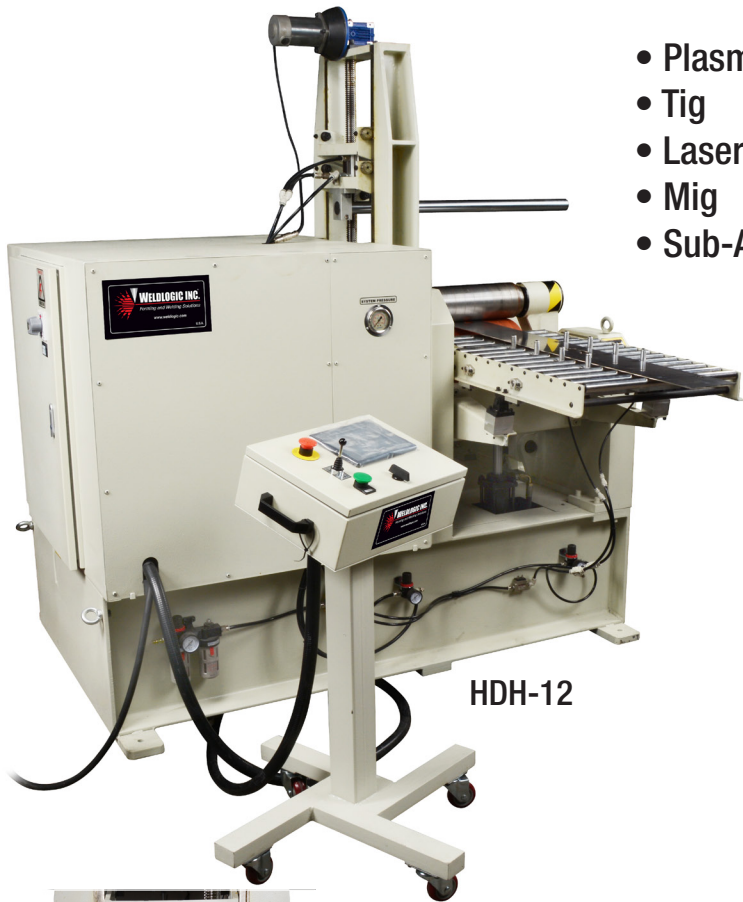

- Plasma
- Tig
- Laser
- Mig
- Sub-Arc



Rugged design and the latest technology combine to enable all operators to produce consistent rolled precision tubes of the highest quality. The precision components and standard features of the PLS seamers provide a highly engineered complete platform for longitudinal welding. Optional features and available programmable welding controls provide unmatched capability for automating the welding process. Contact our engineers to receive free weld process evaluation and sample welds.

Features:

- Easy set up
- Highly repeatable round tubes
- Front and rear safety triggers
- Quick change mandrels
- 24 hour operation
- Digital pressure control
- Heavy duty design
- 100% hydraulically controlled
- Virtually no flats

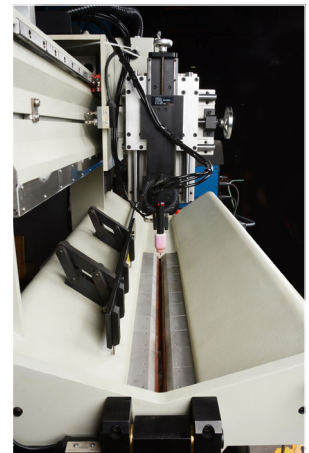

PARTIAL APPLICATIONS LIST

- Electric motor cases
- Filter elements
- Automotive exhaust
- Nuclear vessels
- Vacuum components
- Cryogenic vessels
- Water tanks
- Aircraft components
- Coring drills
- Flexible metal hose

PLS-24 Longitudinal Seam Welder

STANDARD FEATURES INCLUDE:

- AC Servo Carriage Drive Motor
- Reversible Copper Fingers
- Copper Back up bar with Gas Purge capabilities
- Air Actuated retractable Edge Squaring Device
- Foot Pedal Finger Clamping Actuation - Independent left and right actuation
- 8" Square Torch Mount with Cross Seam Adjustment and Automatic Pneumatic Torch Retract
- Carriage mounted Microprocessor Controller
- Precision Ball Bearing Linear track for smooth travel
- Fully Welded Fabrication
- Split Base Foundation - Allowing Owner to add Riser blocks to accommodate larger diameters
- Mandrel end latch safety switch
- Mandrel Vertical adjustment for various thicknesses
- Weld Process Development & Support

OPTIONS

- Water-cooled Mandrel
- Insert gas back-up
- Automatic finger release
- Heavy-duty flexible cable track
- P.L.C. Automation
- Loading cart
- Arc distance control
- Cold wire feed
- Video monitoring
- Laser seam tracking
- Riser Blocks for larger diameters
- Position Based Control

Model	Min Dia.	L	A	B	W	Ship Wt (lbs)
PLS-24	2 5/8"	24"	57"	65"	32"	1,975
PLS-36	3 1/2"	36"	69"	65"	32"	2,200
PLS-48	4 1/4"	48"	81"	65"	32"	3,525
PLS-60	5 1/4"	60"	93"	65"	32"	4,175
PLS-72	5 1/4"	72"	107"	68"	36"	4,625
PLS-84	6 7/8"	84"	126"	68"	36"	4,950
PLS-96	7 1/4"	96"	145"	68"	36"	5,300
PLS-120	9 1/2"	120"	161"	77"	41"	8,800

Contact Weldlogic for your special requirements

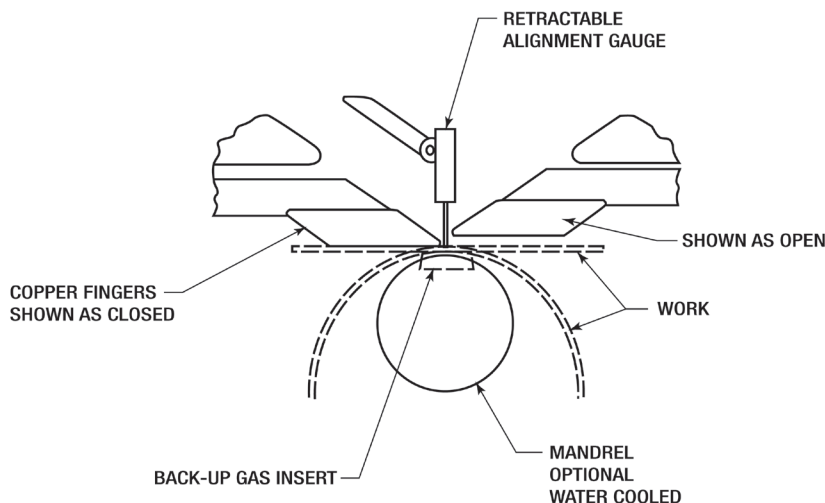
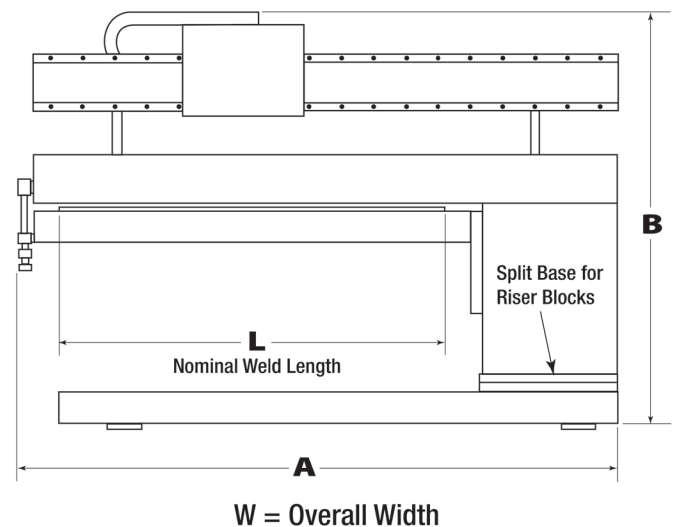

SPECIFICATIONS

- Thickness capacity: 0.005" - 1/2"
- Maximum diameter: 32"
- Torch parallelism: ± .003"
- Speed ranges: 1.5 to 60 IPM/3.0 to 120 IPM
- Speed holding accuracy: ± 0.1%
- Input power requirements: 220v 1-ph, 50/60 Hz
- Compressed air: 80 psi